



35,000 panels - 2018 Winter Olympic Games - PYEONG CHANG - Korea



Olympic Panel

Dimension

DP1201603

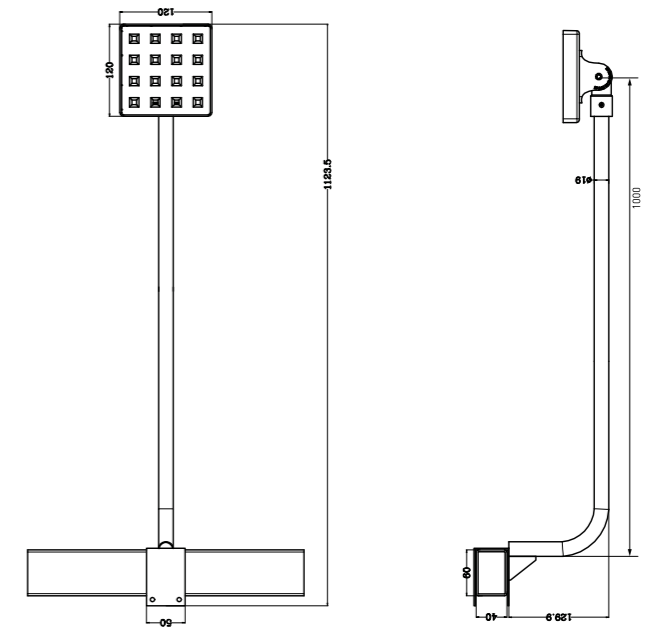

Daytime visible

High-Brightness IP67 SMD RGB 3535 LEDs are used on this panel.



Warranty

5 Year Warranty

Control

Standard DMX512 control protocol (Max 44 frames / second).
The communication between fittings can be synchronised perfectly under use of Titan Artnet Controller.

Protection

Lightning and ESD Protection
Electrical Protections: short circuit, over current, over voltage and over temperature.



Colors

DP1201603



RGB

LED

LED Source	SMD RGB 3535
LED QTY	16pcs
Beam Angle	120Degree

Electrical

Input voltage	12~24VDC
power consumption	2.5W

Control

Protocol	DMX512
Pixels	3 channels per panel
Addressing options	Auto Addressing

Physical

Housing Material	PC(Polycarbonate)	Mounting Options	Intall on the chair with customized holder 4PIN male and 4PIN female screw lock connector bottom entry
Finish	Black	Luminaire Connection	
Lense	Clear		

Environment

Operating Temperature	-30° to 60°	Humidity	0-95%,non-condensing
Startup Temperature	-30° to 60°	IP	Outdoor,IP 67
Storage Temperature	-40° to 80°		

Certificate

CE



RoHS

Permanent Installation

Easy for future maintenance

